

9-11 FEBRUARY 2016
Fiera Milano City
[Mezzanine Hall 5]

The Japan Observatory

What key things do we need to do? What are the focal interests of those surrounding us? And what can be the image of heroes leading our time? This season prioritizes an act to refine human sensitivity, remaining ever-alert to social actuality. Equally significant will be confronting things head-on, making progress and evolving, targeting potential for the reality and future, as living the actual moment based on human-social relationships is key.

“Listen to the unspoken, gaze upon the unseen.”
(Excerpt from ‘the Book of Tea’ by Tenshin OKAKURA)

〈The Japan Fashion Week Organization (JFW)〉, will operate 〈The Japan Observatory〉 in cooperation with 〈The Japan Textile Federation (JTF)〉 and 〈The Japan External Trade Organization (JETRO)〉, and in collaboration with Milano Unica.

〈The Japan Observatory〉 comprises a convergence of specially selected Japanese companies in business booths; totaling 36 companies and groups, PR and Trend booths to showcase trends and an index presenting highlighted fabrics from exhibitors, alongside a special exhibition area introducing “JAPAN CRAFTSMANSHIP -TAKUMI-”.

We proudly introduce premium-quality fabrics representing unprecedented innovation and the spirit of craftsmanship. We sincerely look forward to your visit.

-
- ◆ Period : **9-11 FEBRUARY 2016**
 - ◆ Venue : **Fiera Milano City [Mezzanine Hall 5]**
 - ◆ Organiser : Japan Fashion Week Organization (JFW)
 - ◆ Cooperation : Japan Textile Federation (JTF)
Japan External Trade Organization (JETRO)
 - ◆ Support : Ministry of Economy, Trade and Industry (METI)

Indulgent holiday mood

充実した贅沢な一日の休日

Blissful slow-luxury on an affluent holiday. A moment to reconsider how we live, eat, or nourish and embellish ourselves. A nonchalant interval, further seeking favourites while focusing on self-refinement. Spending a fulfilling time feeling the flowers, soil, wind and air as we perceive surrounding nature. Refining the five senses with appealing self-maintenance and rebirth!

Colours

A resonating and brilliant dynamic palette, with dual facets of audacity and sophistication and accented by a pure-white stroke.



Intersecting music and art - à la mode -

音楽と美術のモードな交差点

A peaceful, enchanting space-time interwoven with music and art, pleurably portrayed in abundant humorous touches. Sonic-artistic euphoria via vibrant, creative coaction inspires a mood that is art-mindful humour awash with pleasant rhythmical stimulations! A modulated performance draws bold and sensitive graphics, while an avant-garde and unconventional mode of dynamism infuses captivating appreciation.

Colours

An elaborately fused palette, audacious yet sensitive and reflecting a rough-natural posture awash with dynamism.



PANTONE® and other Pantone trademarks are the property of Pantone LLC. PANTONE Colors displayed here may not match PANTONE-identified standards. Consult current PANTONE FASHION + HOME Color System Publications for accurate color. Pantone LLC is a wholly owned subsidiary of X-Rite, Incorporated. ©Pantone LLC, 2016. All rights reserved. The above colours may not match PANTONE identified standards because of photocopy, Consult PANTONE TEXTILE Colour System™ for accurate colours.

-The Japan Observatory- Exhibitors' List

Booth No.	Name of company/association	Main industrial production	URL
J22	A-GIRL'S CO., LTD.	Cotton, wool, silk, linen/ramie, cashmere	www.agirls.co.jp/
J13	AOBUN TEXTILE CO., LTD.	Stretch polyester, cotton, acetate	www.aobuntex.com/
J23	FUJIMOTO YASUICHI SHOTEN CO., LTD.	Japanese modern tie-dye leather (for clothing)	-----
J02	FUKUDA ORIMONO, LTD.	Cotton weaving "fine & light" and "compact multiple weave"	www.fukudaorimono.jp/ www.fukuda-textile.com/
J21	FUKUI-PREF KNITTING INDUSTRY ASSOCIATION	Synthetics and blends, warp-knitted fabrics	f-ami.jp/
	HATTA WARP KNITTING CO., LTD.	Double raschel, tricot, 3D, warp knitting	www.8ta.co.jp
	MIKUNI TRICOT CO., LTD.	Cotton, wool	-----
J11	FURUHASHI WEAVING CO., LTD.	Cotton, wool, bamboo, linen, Manila fiber and interwoven fabrics	www.furuhashi-weaving.jp/
J11	HAYASHIYO CO., LTD.	Linen textiles	www.hayashiyo.com
J06	ICHINOMIYA FASHION DESIGN CENTER FOUNDATION	Wool and blends	www.fdc138.com/
	NAKADEN KEORI CO., LTD.	Wool and blends	www.nakadenkeori.co.jp
	TOYAMA & CO., LTD.	Wool, wool blends, cashmere, fine wosted, high count silk, linen blends	www.toyamasangyo.co.jp
J09	ITOCHU CORPORATION HOKURIKU TEXTILE SECT.	Synthetics, cotton, linen and others	www.itochu.co.jp
J24	KANEMASA KNITTING CO., LTD.	New-type knit fabrics for shirt and suiting	www.kanemasa-inc.jp
J23	KAZEKAMI KNITTING CO., LTD.	Stretch french terry, wool french terry, linen french terry	www.kazekami-knitting.jp/
J26	KUMAZAWA SHOJI CO., LTD.	Triacetate blends	www.kmz.co.jp/
J13	MIYASHIN CO., LTD.	Silk and blends	tango-miyashin.com
J25	NISHIMURA LACE CO., LTD.	Raschel lace, jacquard lace, lace with various finishing	www.lilylace.co.jp
J12	SAIEI ORIMONO CO., LTD.	Silk fabrics	www.saiei-orimono.com
J07	STYLEM CO., LTD.	Cotton, wool, linen & ramie, synthetics, knits, lace, embroidery and others	www.takisada-osaka.co.jp/
J01	SUNWELL CO., LTD.	Wool, wool-linen blends, cotton, knits, linen, cupra, tencel, polyester	www.sunwell.jp
J10	TAKISADA-NAGOYA CO., LTD.	High density knit, stretch fabrics	www.takisada-nagoya.jp/
J12	TATSUMI WEAVING CO., LTD.	Cotton, cotton-blends (polyester, nylon, triacetate, cupra), linen	www.tatsumi.jpn.com
J14	TOKO SHOJI CO., LTD.	Knits (french terry, jacquard etc), raschel lace, denim and others	www.tokoshoji.co.jp
J03-J05	TORAY INDUSTRIES, INC.	Synthetics	www.toray.com/
J17-J20	TORAY SYNTHETIC TEXTILE CLUSTER	Synthetic textiles etc.	www.gosen-cluster.com/
	FUKUI WARP KNITTING CO., LTD.	3D spacer fabrics, bi-stretch fabrics, weft insertion technique	www.fukutate.co.jp
	KAYTAY TEXINNO INC.	Synthetics, functional fabrics	www.kaytay.co.jp/
	KOMATSU SEIREN CO., LTD.	Synthetics and blends	www.komatsuseiren.co.jp/en/index.html
	MARUI ORIMONO CO., LTD.	Textile of synthetic fibres particularly polyamide	www.maruig.co.jp
	MATSUBUN TEXTILE CO., LTD.	Synthetics and blends	www.matsubun.co.jp
	SAKAI OVEX CO., LTD.	Nylon & polyester fabrics	www.sakaiovex.co.jp/
TEC ONE CO., LTD.	Nylon, polyester, polyurethane film	www.tecone.co.jp	

-The Japan Observatory- Layout of Exhibitors

Booth No.	Name of company/association	Main industrial production	URL
J15-J16	UNI TEXTILE CO., LTD.	Synthetics, cotton, lace & embroidery, bonded fabrics, knits and others	www.komon-koubou.com/
J08	YAGI TSUSHO LIMITED	Cotton, synthetics, wool, Japanese denim	www.yagitsu.co.jp/
J27	YAMANASHI TEXTILE ASSOCIATION	Silk, cotton, linen, ramie, synthetics and blends	yamanashi-tex.jp/
	KAIKIZA	Organic cotton and blends, synthetic fiber jacquard	maedagen.sub.jp/recruit/philosophy/
	KAWAEI CO., LTD.	Silk, synthetics and blends	kawaei.neckwear.co.jp/global/
	MIYASHITA ORIMONO CO., LTD.	Silk, synthetics and blends	www.miyashita-orimono.jp/
J24	YOSHIDA SENKO CO., LTD.	Fabrics made of organic cotton or regular cotton	www.yoshidasenko.com/

JAPAN
Observatory

Fiera Milano City [Mezzanine Hall 5]

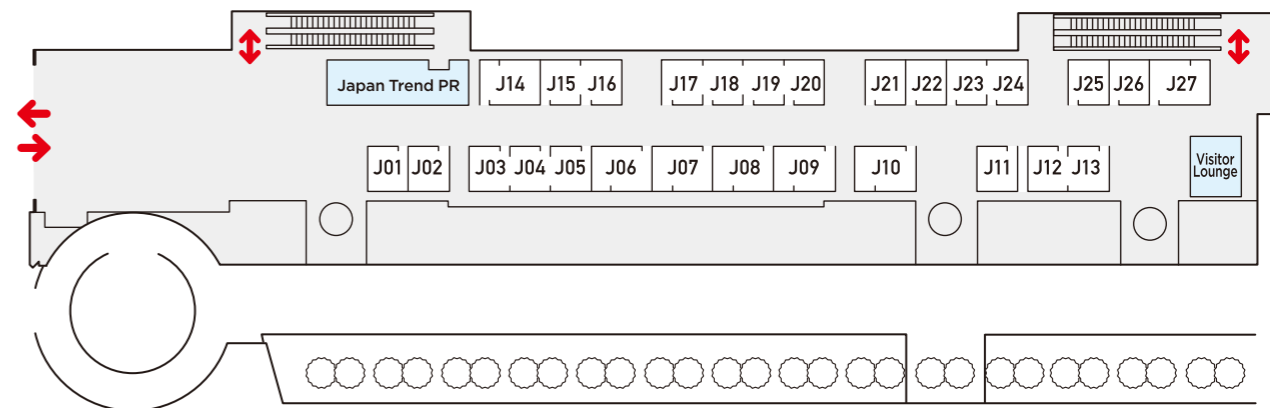



JAPAN CRAFTSMANSHIP – TAKUMI –

The graceful elegance of Japanese beauty, enriched by seasonal natural wealth alongside cutting-edge technology, has created unique and unrivalled sensitivity through intermingled global culture. In the textile field, fabrics retaining an ever-delicate and expressive nature; the fruit of sensitivity imbued in craftsmanship and elaborate skills uniquely established in Japan, have been globally acclaimed. We proudly present the special exhibition ‘JAPAN CRAFTSMANSHIP – TAKUMI –’ at 〈The Japan Observatory〉, following on from the previous season, introducing specific companies and textile production regions that retain our treasured high technicity and sensitivity, in the hope of boosting awareness of Japan Craftsmanship – TAKUMI – among all visitors to the venue.

A-GIRL’S CO., LTD. (Stand No. J22)
FURUHASHI WEAVING CO., LTD. (Stand No. J11)
HAYASHIYO CO., LTD. (Stand No. J11)

Special movie to be played
(Audio : Italian / Subtitles : English)

Venue / Mezzanine Hall 5 - JFW Visitor Lounge



Japan Fashion Week Organization (JFW Organization)

The Japan Fashion Week Organization (JFW Organization) aims to further strengthen the competitive power of the Japanese textile and fashion industry, and to encourage its growth. Moreover, we further increase Tokyo’s reputation as the world’s textile and fashion base by promoting excellent Japanese textile and fashion products, and by sending comprehensive information around the world. Furthermore, we aim to enhance Tokyo as the center of fashion business in Asia.

JFW Organization brings together manufacturers in the textile and fashion industries, fashion designers and distributors that share the same passion to collaborate and conduct the following businesses with “creativity”, “craftsmanship”, and “trading” at its foundation.

- Collection Business (Mercedes-Benz Fashion Week TOKYO)
- Textile Business (Premium Textile Japan, JFW JAPAN CREATION)

www.jfw.jp/en/
www.ptjapan.com/english/index2.html
www.japancreation.com/english/index2.html

■Contact

Japan Fashion Week Organization
8F, Kanou.5th Bldg., 3-26-16 Shibuya, Shibuya-ku, Tokyo 150-0002, JAPAN
Tel: +81-3-6805-0791 Fax: +81-3-6805-0793

